

Mounting Hardware Kit for Mosaic

PRODUCT INFORMATION

Description	Mounting Hardware Kit for Mosaic
Mounting Hardware Description	(x1)
Product Weight	0.20 lbs / 0.09 kgs
Shipping Weight	2.25 lbs / 1.02 kgs



PRODUCT DIMENSIONS

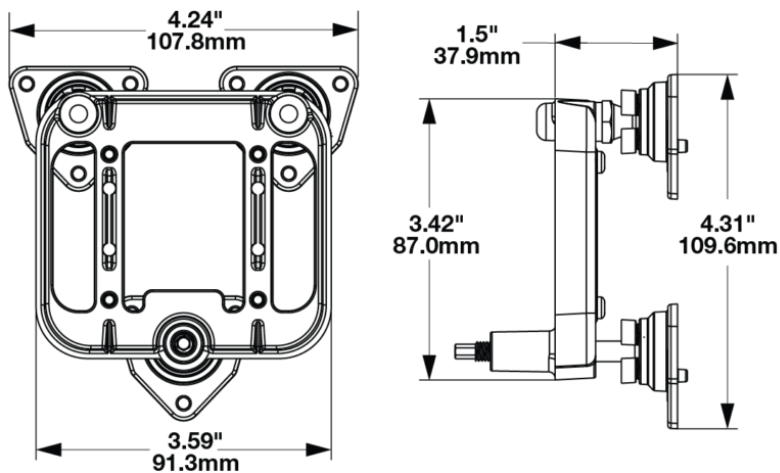

Print date: 2025-03-12

© 2025 J.W. Speaker Corporation • Germantown, WI U.S.A.
www.jwspeaker.com • speaker@jwspeaker.com • 262.251.6660

Mounting Hardware Kit for Mosaic

INSTALLATION & APPLICATION INFORMATION

The 8200831 Mounting Hardware Kit is usable with all lights except the Vertical and Horizontal Low Beam Headlights:
0561411(2)
0561421(2)
0561401(2)

ADDITIONAL INFORMATION

JWS PODULE MODEL 92 MOUNTING HARDWARE KIT includes”
BRACKET, LB AIM qty 1
STUD, BALL 10mm, OVERMOLDED qty 2
ADJ ROD 10MM DIA X 63.5MM.w/HEX qty 1
SCREW, #6-32X.5,CR,TX,ST,BZN,AQ qty 4
92 MOUNT 10mm BALL SOCKET EXT qty 3
ADJUSTER BALL SOCKET 10MM qty 3
This kit does not come with model 93 lamps - only the Mounting Assembly

PRODUCT WARNINGS

For California residents:

⚠ **WARNING:** Cancer and reproductive harm - www.P65Warnings.ca.gov.

⚠ **AVERTISSEMENT:** Cancer et effet nocif sur la reproduction - www.P65Warnings.ca.gov.

SUITS THESE PRODUCTS

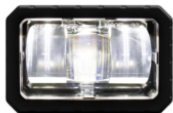

Customizable Modular LED Lights

LED Mosaic Modular
Lighting System -
Model 92

Print date: 2025-03-12

© 2025 J.W. Speaker Corporation • Germantown, WI U.S.A.
www.jwspeaker.com • speaker@jwspeaker.com • 262.251.6660