

LED Clearance & Marker Lights – Model 173

PRODUCT INFORMATION

Description	12-24V LED Amber Vertical Reflex & Marker Lights - Bulk Qty (48 MIN)
Height	41.20 mm / 1.62 in
Width	114.40 mm / 4.5 in
Depth	28.10 mm / 1.11 in
Shape	Rectangular
Outer Lens Material	Acrylic
Outer Lens Color	Amber
Housing Material	Polycarbonate / ABS Plastic
Housing Color	White
Mounting Hardware Description	Will accept up to M5 or #10 mtg hardware
Mounting Type	Vertical Flush
Connector or Wiring	Deutsch DTM04-2P
Mating Connector	Deutsch DTM06-2S
Product Weight	0.25 lbs / 0.11 kgs
Shipping Weight	11.75 lbs / 5.33 kgs

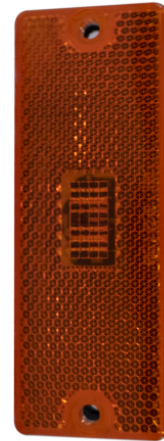

PRODUCT DIMENSIONS

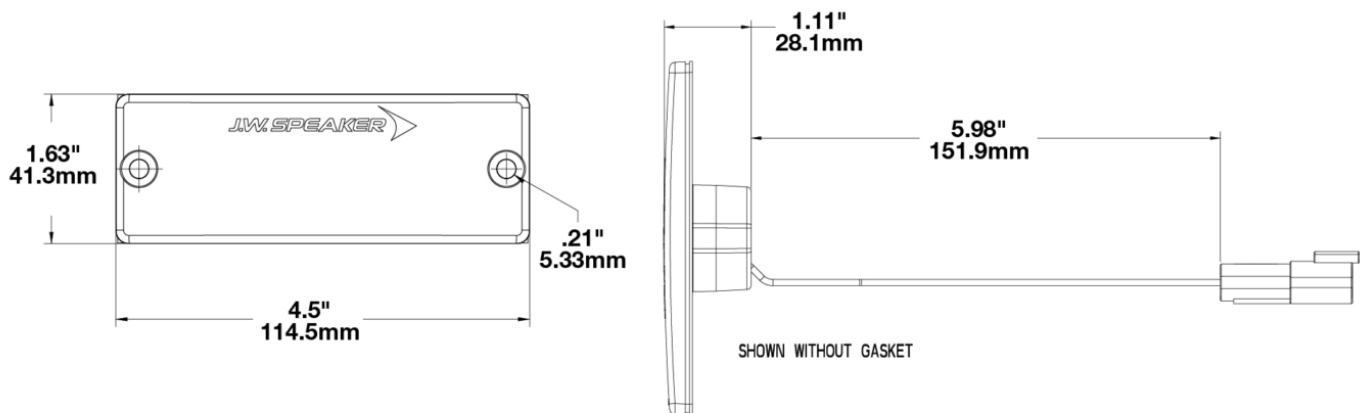

Print date: 2025-02-05

© 2025 J.W. Speaker Corporation • Germantown, WI U.S.A.
www.jwspeaker.com • speaker@jwspeaker.com • 262.251.6660

J.W. SPEAKER
Engineered. Lighting. Solutions.

LED Clearance & Marker Lights – Model 173

ELECTRICAL SPECIFICATIONS

Input Voltage	12-24V DC
Operating Voltage	10-30V DC
Red Wire	Positive
Black Wire	Ground
Current Draw	.072A @ 12V DC .072A @ 24V DC

REGULATORY STANDARDS COMPLIANCE

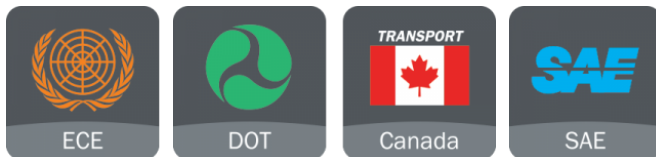

ECE Reg 3	ECE Reg 91
FMVSS 108 s7.4 (Table X)	SAE J592
SAE J594	

PHOTOMETRIC SPECIFICATIONS

Beam Pattern(s) Signalization - Marker

APPLICATIONS

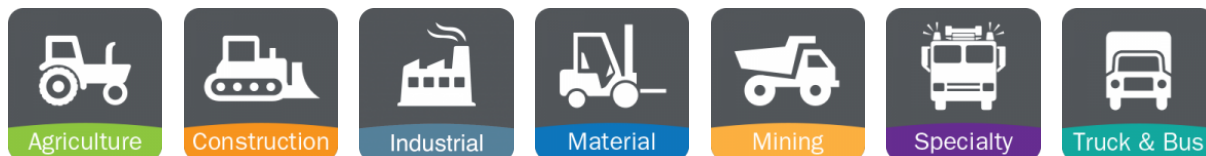

PRODUCT WARNINGS

For California residents:

⚠ WARNING: Cancer and reproductive harm - www.P65Warnings.ca.gov.

⚠ AVERTISSEMENT: Cancer et effet nocif sur la reproduction - www.P65Warnings.ca.gov.

Print date: 2025-02-05

© 2025 J.W. Speaker Corporation • Germantown, WI U.S.A.
www.jwspeaker.com • speaker@jwspeaker.com • 262.251.6660

J.W. SPEAKER
Engineered. Lighting. Solutions.

LED Clearance & Marker Lights – Model 173

RELATED PRODUCTS



Part Number

0230862

12-24V LED Amber
Horizontal Reflex and
Marker Lights - Bulk
Qty (48 MIN)